



## CALCULATION OF THE TEMPORAL EVOLUTION OF SOUND PRESSURE LEVELS IN ROOMS

PACS: 43.55.Ka

Cazard, Guillaume; Senat, Claude; Gamba, René  
Gamba Acoustique & Associés, buro parc2, BP 163 31676 Labege cedex, France;  
[guillaume.cazard@acoustique-gamba.fr](mailto:guillaume.cazard@acoustique-gamba.fr)

### ABSTRACT

This paper describes a model which enables the temporal evolution of sound pressure levels in rooms to be calculated. It is built on the assumption that sound waves are totally scattered when reflected by the walls. This model prescribes the sampling of all the surfaces of the room and defines a process of time discretization, process which enables the temporal evolution of energetic exchanges between each sample to be known. Ultimately, the model allows the sound pressure level to be calculated in every point of the room for each time sample (echograms). Thanks to the echograms, some useful criterias for room acoustic studies can be evaluated : reverberation time, EDT, D50, C80,... Measurements and calculations have been carried out for different kinds of rooms. We will describe them in the second part of this paper.

### 1. INTRODUCTION

Room acoustic studies need to take into account many criteria which the most used is the reverberation time (RT60). The reverberation time of a room is generally calculated from the echograms. Our paper describes a model which enables the echograms to be calculated according to the assumption that sound waves are totally scattered when reflected by the walls. A first part describes the formalism of the model and a second part describes the process we have chosen to build an iterative formula based on wall surfaces and time sampling. Ultimately, calculations and measurements of reverberation times, carried out for different kinds of rooms, will be compared.

### 2. OUR MODEL TO CALCULATE THE TEMPORAL EVOLUTION OF THE ACOUSTIC INTENSITY

The models for predicting the sound field based on specular reflection assumptions use infinitely smooth surfaces. However, in the case of rough surfaces and dimensions less than the wavelength, experiments have shown that specular reflection of the sound no longer applies. Walls of the majority of the rooms are seldom smooth and flat : presence of furniture, shape of the building materials, floor cluttering... To take account of these conditions, a diffuse reflection model has to be used. Our model is built on the assumption that the sound waves are totally scattered when reflected by the walls.

#### **Influence of a surface component on another one**

Our model assumes [1], [2], [3], [4] that the intensity of the noise at any point consists of two superposed components, a direct component consisting of the intensity of the noise emitted directly by the source, and a component of noise reverberated from the walls. The first component, which is easily determined, corresponds to the free field propagation of spherical waves, the theoretical model for which is well known. The second component (reverberated noise) requires the assimilation of the walls as point sources (virtual) the directivity of which takes account of the diffusion assumption.

The directivity factor of the diffused reflection used by our model is:

$$Q(\theta) = 4\cos\theta \quad (\text{Eq.1})$$

Each component of a surface which receives energy retransmits it towards all the surface components. Let us examine two components  $dS$  and  $dS'$  centred respectively on  $x$  and  $x'$ ,

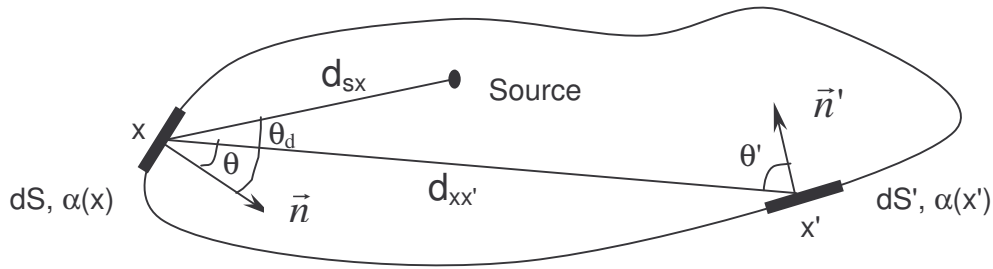

Fig. 1. influence of a surface component on another one

These elements are both characterized by their absorption coefficients  $\alpha(x)$  and  $\alpha(x')$ . The surface density of incident power on  $dS$ , noted  $dI(t,x)$  and induced by  $dS'$ , is:

$$dI(t,x) = \frac{I\left(t - \frac{d_{xx'}}{c}, x'\right) (1 - \alpha(x')) \cos\theta' \cos\theta dS'}{\pi d_{xx'}^2} \quad (\text{Eq.2})$$

$\cos\theta$  is the solid angle according to which  $dS$  is seen by the incoming flux  $I(x')$  is the surface density of incident power on  $dS'$ , only the fraction  $I(x')(1 - \alpha(x'))$  of which is re-emitted.

In order to simplify the formula, we have grouped the geometrical terms within the same coefficient, that we can call the influence coefficient  $K(x,x')$ .

$$K(x,x') = \frac{\cos\theta \cos\theta'}{\pi d_{xx'}^2} \quad (\text{Eq.3})$$

The surface density of incident power on  $dS$  induced by all the walls is therefore :

$$I(t,x) = \int_S K(x,x') I\left(t - \frac{d_{xx'}}{c}, x'\right) (1 - \alpha(x')) dS' \quad (\text{Eq.4})$$

This expression would not be complete if we did not take into account the intensity of the source received directly by  $dS$ . This intensity is represented by  $I_{d,x}(t)$

Therefore we obtain :

$$I(t,x) = \int_S K(x,x') I\left(t - \frac{d_{xx'}}{c}, x'\right) (1 - \alpha(x')) dS' + I_{d,x}(t) \quad (\text{Eq.5})$$

### Intensity at the receptor

The intensity received in every point has 2 components. The first one is the intensity directly received from the source (free field propagation). The second one is the intensity coming from all the surface components  $dS$  of the room.

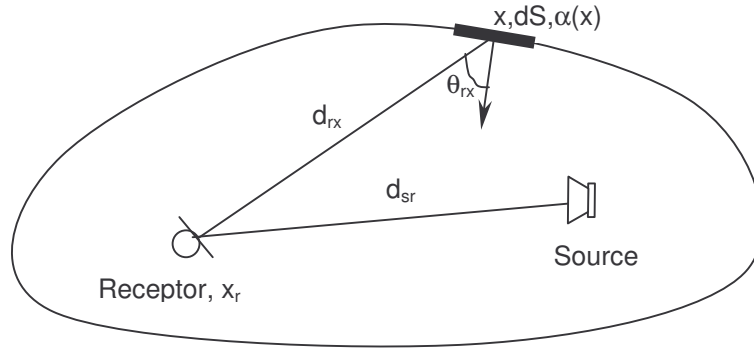

Fig. 2. Intensity received by the receptor

The intensity received at any point of the room for each time is:

$$I_R(t, x_R) = Id_{SR}(t) + \int_S \frac{I\left(t - \frac{d_{rx}}{c}, x\right) (1 - \alpha(x)) \cos \theta_{rx} dS}{\pi d_{rx}^2} \quad (\text{Eq.6})$$

where  $Id_{SR}(t)$  is the acoustic intensity directly received at the receptor from the source.

The pressure level is obtained by:

$$L_p(t) = 10 \log \left( \frac{I_R(t)}{10^{-12}} \right) \quad (\text{Eq.7})$$

### 3. SETTING UP AN ITERATIVE FORMULA

In order to overcome the integral and allow the equation to be solved numerically, the walls have to be discretised. Therefore the walls have to be broken down into N surface samples by considering that:

- the absorption coefficient  $\alpha$  is constant for a same sample
- the surface power density is constant on all the surface  $S_i$  of the sample
- each surface sample will be identified by its centroid.

Thus, the surface power density is expressed by:

$$I_i(t) = \sum_{j=1}^N I_j \left( t - \frac{d_{ij}}{c} \right) (1 - \alpha_j) K_{ij} + Id_i(t) \quad (\text{Eq.8})$$

Setting up an iterative formula needs the sampling of the time axis. The time sample is noted k.

The temporal shift  $\frac{d_{ij}}{c}$  is sampled as following:

$$m_{ij} = \text{int} \left( \frac{d_{ij}}{c \Delta t} \right) \quad (\text{Eq.9})$$

where  $\Delta t$  is the temporal sampling step (expressed in second). The « int » function gives the closer rounded integer for the quantity  $\frac{d_{ij}}{c \Delta t}$ .

The equation (Eq. 8) is now written:

$$I_i(k) = \sum_{j=1}^N (1 - \alpha_j) I_j(k - m_{ij}) K_{ij} + Id_i(k) \quad (\text{Eq.10})$$

Thus, the intensity in every point of the room is :

$$I_R(k) = Id_{SR}(k) + \sum_{i=1}^N (1 - \alpha_i) I_i(k - m_{ri}) \frac{\cos \theta_{ri} S_i}{\pi d_{ri}^2} \quad (\text{Eq.11})$$

#### 4. COMPARISON BETWEEN CALCULATIONS AND IN SITU MEASUREMENTS

Reverberation times calculated with our model for 4 different rooms are given in this chapter. The rooms studied present various geometries and acoustical treatments. Those calculations will be compared with in situ measurements. Our model allows the calculation of the echogram. The reverberation time is deduced from it thanks to the slop of the late exponential decrease. The figure below shows an echogram calculated with our model.

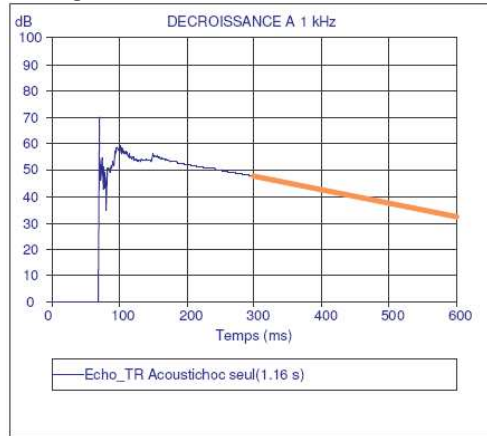

Fig. 3. Echogram at 1 kHz

#### Room #1 : Halle aux Grains - Samatan (32-France)

This is both a theatre and a concert hall. Its volume is 1,500 m<sup>3</sup> and its floor surface is 250 m<sup>2</sup>. Various absorbent materials are distributed on the ceiling, on the walls and on the floor (sits).

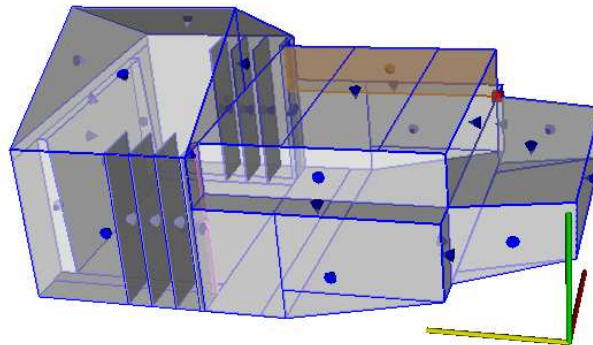

Fig. 4. modelisation of the room

Calculated and measured values (for the same couple of source and receptor) are presented in the table below:

	125 Hz	250 Hz	500 Hz	1000 Hz	2000 Hz	4000 Hz
Measurement (s)	0.77	0.64	0.67	0.69	0.78	0.81
Calculation (s)	0.84	0.69	0.7	0.66	0.64	0.6

Fig. 5. Reverberation times

#### Room #2 : Théâtre des 3 ponts - Castelnaudary (11-France)

This is both a theatre and a concert hall. Its volume is 2,140 m<sup>3</sup> and its floor surface is 290 m<sup>2</sup>. Various absorbent materials are distributed on the ceiling, on the walls and on the floor (sits).

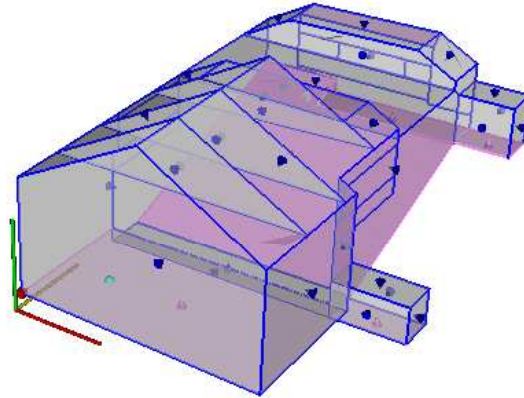

Fig. 6. modelisation of the room

Calculated and measured values (for the same couple of source and receptor) are presented in the table below:

	<b>125 Hz</b>	<b>250 Hz</b>	<b>500 Hz</b>	<b>1000 Hz</b>	<b>2000 Hz</b>	<b>4000 Hz</b>
Measurement (s)	0.83	0.58	0.61	0.75	0.73	0.64
Calculation (s)	0.84	0.57	0.59	0.72	0.69	0.64

Fig. 7. Reverberation times

**Room #3 : Cezus factory - Montreuil (49-France)**

This factory is 20 m wide and 140 m long. Its volume is 24,660 m<sup>3</sup> and its floor surface is 2,900 m<sup>2</sup>.

Various materials highly absorbent are distributed on the ceiling and on the walls. The floor is cluttered with many machine-tools.

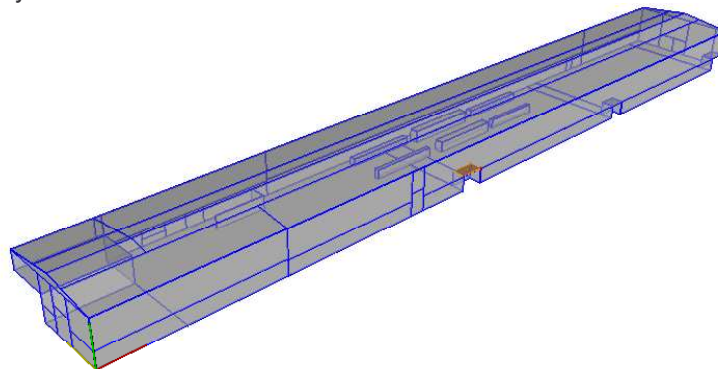

Fig. 8. modelisation of the factory

Calculated and measured values (for the same couple of source and receptor) are presented in the table below:

	<b>250 Hz</b>	<b>500 Hz</b>	<b>1000 Hz</b>	<b>2000 Hz</b>	<b>4000 Hz</b>
Measurement (s)	1.24	1.28	1.59	1.45	1.18
Calculation (s)	1.35	1.24	1.39	1.55	1.41

Fig. 9. Reverberation times

**Room#4 : Havana Café – Toulouse (31-France)**

This is a concert hall used for loud music. Its volume is 6,090 m<sup>3</sup> and its floor surface is 870 m<sup>2</sup>. Various absorbent materials are distributed on the ceiling and on the walls.

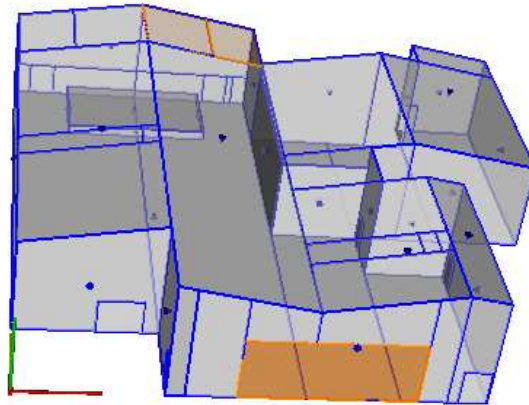

Fig. 10. modelisation of the room

Calculated and measured values (for the same couple of source and receptor) are presented in the table below:

	<b>125 Hz</b>	<b>250 Hz</b>	<b>500 Hz</b>	<b>1000 Hz</b>	<b>2000 Hz</b>	<b>4000 Hz</b>
Measurement (s)	0.96	0.91	0.90	1.18	1.36	1.29
Calculation (s)	1.10	0.94	0.88	0.96	1.39	1.21

Fig. 11. Reverberation times

For those 4 rooms, calculated reverberation times are close to in situ measurements. Moreover, the results show that the accuracy of the values given by our model is adapted for room acoustic studies.

## 5. CONCLUSIONS

The model presented in this paper allows the calculation of the echograms of a room. It is built on the assumption that sound waves are totally scattered when reflected by the walls. Thanks to the echograms, reverberation times can be deduced. Calculations and measurements had been carried out for different kinds of rooms and show that the accuracy of the values given by our model is adapted for room acoustic studies.

Other criteria would be calculated with the echograms given by our model as, for example, EDT, C80, D50 or RASTI.

## References

- [1] CAZARD G. : « Elaboration d'une algorithmique permettant de déterminer la réponse temporelle d'un local en se basant sur l'hypothèse de réflexion diffuse en paroi » - Rapport de DEA Acoustique. Université Paul Sabatier – Toulouse (2002).
- [2] SENAT C. : « Prise en compte de l'encombrement, au sein d'un modèle de prévision des niveaux de pression, reposant sur l'hypothèse de réflexion diffuse sur les parois ». Thèse de Doctorat spécialité acoustique de l'Université Paul Sabatier – Toulouse (1992).
- [3] MALCOURT C. : « Simulations informatiques pour prédire les critères de qualification acoustique des salles. Comparaison des valeurs mesurées et calculées dans une salle à acoustique variable ». Thèse de 3e cycle spécialité acoustique. Université Paul Sabatier – Toulouse (1986).
- [4] ZULIANI P. : « Elaboration d'un modèle prévisionnel fondé sur l'hypothèse de réflexion diffuse en paroi ». Rapport de DEA Acoustique. Université Paul Sabatier – Toulouse (1986).
- [5] PICAUT J., SIMON L., POLACK J-D : « A mathematical model of diffuse sound field based on a diffusion equation ». *Acoustica* Vol. 83 (1997) 614-621.
- [6] KUTTRUFF H. : « Energetic sound propagation in rooms ». *Acoustica* Vol. 83 (1997) 622-628
- [7] SCHROEDER M.R. : « Iterative calculation of reverberation time » *Acoustica* Vol. 45 (1980)
- [8] GILBERT : « Iterative calculation of reverberation time » *JASA* 69 (1) (1981)